

EFB Wall hung Gas-fired Condensing Boilers



- Outputs from 85 to 151kW at 50/30°C system design
- High efficiency condensing technology
- Stainless steel heat exchanger
- Ultra Low NO_x emissions ≤24mg/kWh
- Capable of operating at ΔT of up to 30°C
- Integral controls
- Cost effective flue options

Lochinvar

EFB Gas-fired Condensing Boilers

With 4 models to choose from, EFB wall hung, gas-fired condensing boilers are available in outputs ranging from 85 to 151kW; based upon a system design of 50/30°C. Operating at seasonal efficiencies of up to 96% (Gross CV), all models feature a pre-mixed burner, which will modulate down to 20% of output and accurately matches heat output to demand. This ensures that optimum efficiency is maintained even in part load demand periods.

EFB boilers can be either wall or frame mounted and at only 440mm wide and 539mm deep, provide a compact, space-saving solution for commercial, industrial and large residential buildings.



EFB Boiler
4 models

Stainless Steel Heat Exchanger

At the heart of the EFB boiler is a **high quality heat exchanger made from stainless steel**; a material which provides high levels of resistance to corrosion. The heat exchanger can operate at working pressures of up to 6 bar and peace of mind is provided with our 5+5 heat exchanger warranty; in addition to the 5-year warranty, we also provide additional support from years to 6 to 10 on a sliding scale basis.



Ultra low NO_x emissions

Air quality has become an ever-increasing challenge for society in recent years and legislative changes mean that maximum permitted levels of NO_x emissions from gas-fired boilers are now lower than ever. Sustainable projects in the UK are often subject to BREEAM assessment and the 2018 New Construction Technical Manual SD5068 for non-domestic buildings tightened up considerably on permitted levels of NO_x emissions. Not only does the EFB range comply, with **NO_x emissions lower than 24mg/kWh across the range, they qualify for the maximum 2 BREEAM credits.**

Integral controls for efficient operation

System design and control are both vitally important aspects of achieving operating efficiencies for which most modern gas-fired boilers are capable; the integral controls within the EFB range provides a cost effective solution, with or without the requirement for BMS

Key features of the integral EFB controls include

- Cascade control – up to 16 boilers in one cascade
- On/off 0-10v fault and run signalling
- Modulating pump control
- Remote enable

Operation at ΔT of up to 30°C

With a simple parameter change which can be made during commissioning, the EFB boiler can be configured to operate at ΔT of up to 30°C. As the boiler return temperature will always be 50°C or lower, this key feature provides a significant benefit to the end user. It means the EFB boiler will operate in virtually continuous condensing mode, providing highest possible levels of efficiency and reducing energy consumption

Cascade Multi-boiler installations

This type of installation has become commonplace for many commercial applications, where multi boiler installations are popular. Cascade systems like this provide many end user benefits, where the integral controls ensure that boilers modulate according to system demand, providing the highest levels of system efficiency. They also provide stand-by in the event of individual boiler lockout.

EFB is capable of installation in up to 16-boiler cascade systems.

Each boiler incorporates a non-return valve within the combustion system preventing the recirculation of flue gas on a multiple installation.

Dimensional Drawings

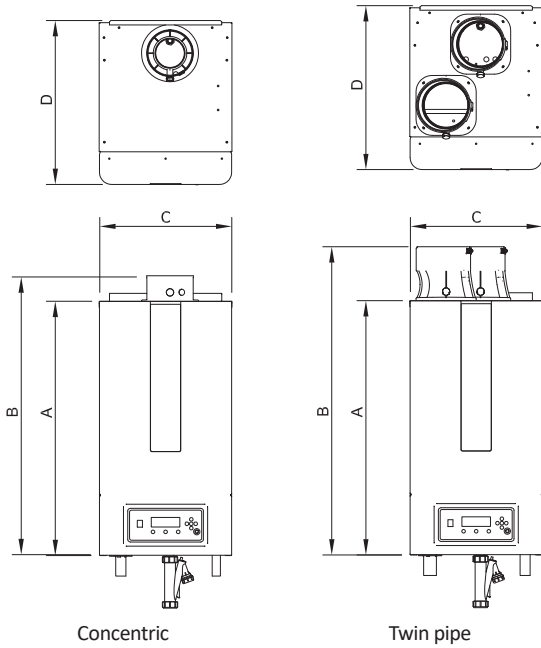

Dimension		EFB85	EFB105	EFB125	EFB155
A	Height to top of case	845	845	845	845
B	Height to flue outlet (Concentric)	931	931	931	n/a
B	Height to flue outlet (Twin-pipe)	1065	1065	1065	1025
C	Width	440	440	440	440
D	Depth	539	539	539	539

Flue Options

Another feature of the EFB boiler range is its ability to be installed with a range of flue types, including room-sealed concentric or twin pipe and traditional conventional flue systems.

Connections		Twin pipe			
		EFB85	EFB105	EFB125	EFB155
Flue gas	mm	100-100			150-150
Air inlet		100-100			150-150
flow	Inch	R1"			R1½"
condensate	mm	flexible hose Ø25/21 mm			
return	Inch	R1"			R1½"
gas	Inch	R¾"			R1"
Connections		Concentric			
		EFB85	EFB105	EFB125	EFB155
Flue gas	mm	100-150			n/a
Air inlet		100-150			n/a
flow	Inch	R1"			R1½"
condensate	mm	flexible hose Ø25/21 mm			
return	Inch	R1"			R1½"
gas	Inch	R¾"			R1"

Boiler Frame and Pipework Manifold Ancillary Option

This type of boiler is often installed in multiples and in modular arrangements and we have a full range of Frame and Pipework assemblies available from 2-boiler to 6-boiler installations. These ancillary items include:

- Mounting frame
- Flow/return and gas manifold pipework
- Inter-connecting pipework to each boiler
- Low velocity header
- Optional: Matched modulating boiler pump

Modular boiler installations can help to reduce installation time, and a key feature of EFB mounting frame assemblies is that the **total frame height is less than 1.8m**. This can provide key assistance with installation and maintenance especially in plant rooms with restricted height.



Technical Specification

Boiler model		EFB85	EFB105	EFB125	EFB155
Nominal Input (Gross) min-max	kW	17.1 - 90.7	20.7 - 108.1	26.2 - 132.6	38.9 - 161.4
Nominal Input (Nett) min-max	kW	15.4-81.7	18.6-97.3	23.6-119.4	35.0-145.3
Gas Flow Rate (Natural Gas)	m ³ /hr	1.6 - 8.5	1.9 - 10.2	2.5 - 12.5	3.7 - 15.3
Output @50/30°C min-max	kW	16 - 85.1	19.5 - 101.8	24.7 - 124.7	36.4 - 151.0
Output @80/60°C min-max	kW	14.9 - 79.1	18 - 94.2	22.9 - 115.7	33.9 - 140.9
Efficiency Data - Building Regulations					
Seasonal Efficiency (Gross CV)	%	96	96	96	96
Efficiency Data - ErP and Energy Label					
Ecodesign Energy Label rating		n/a	n/a	n/a	n/a
Seasonal space heating energy efficiency	%	92.4	92.6	92.7	92.9
NO_x Emissions					
NO _x emissions (according to EN15502)@0% O ₂	mg/kWh	23.1	21.3	23.9	20.1
NO _x class according to EN15502		6			
General Data					
Dimensions (Height)	mm	845	845	845	845
Dimensions (Width)	mm	440	440	440	440
Dimensions (Depth)	mm	539	539	539	539
Water Content	litres	5.0	6.5	8.3	10.4
Weight (Empty)	kg	77	79	83	86
Weight (Full)	kg	82.0	85.5	91.3	96.4
Flow Connection (Inches)	BSP	R1"	R1"	R1"	R1½"
Return Connection (Inches)	BSP	R1"	R1"	R1"	R1½"
Gas Connection (Inches)	BSP	R¾"	R¾"	R¾"	R1"
Flue connection (Concentric)	mm	100/150	100/150	100/150	n/a
Flue connection (Twin-pipe)	mm	100/100	100/100	100/100	150/150
Electrical Requirements		230V /1Ph/ 50hz			
Maximum Power Consumption	W	190	280	280	280
Sound Power Level	LWA(db)	65,8	68	67,8	73
Nominal Flue Gas Temperature	°C	60-90	60-90	60-90	60-90
Max Flow Temperature	°C	90	90	90	90
Working Pressure Minimum	bar	1	1	1	1
Working Pressure Maximum	bar	6	6	6	6

Energy Label, Product Fiche and ErP Data Table are available at www.lochinvar.ltd.uk

Ancillary Items – optional

- Pressurisation units
- Heating system separators
- Outdoor temperature sensor
- Flow temperature sensor
- Matched primary circulation pumps
- Mounting Frame and Pipework assemblies
- Expansion vessels

Complementary Products for the generation of Domestic hot water

- Direct gas-fired Water Heaters
- Indirect Water Heaters/Calorifiers
- Packaged Plate Heat Exchangers

For further information on the EFB Boilers, including ICM & User Instructions and our full Warranty Terms and Conditions, please visit our website: www.lochinvar.ltd.uk



Lochinvar Ltd reserves the right to change specifications without prior notice

